

TF-14[®]

Trench Drain Forming System Design Manual

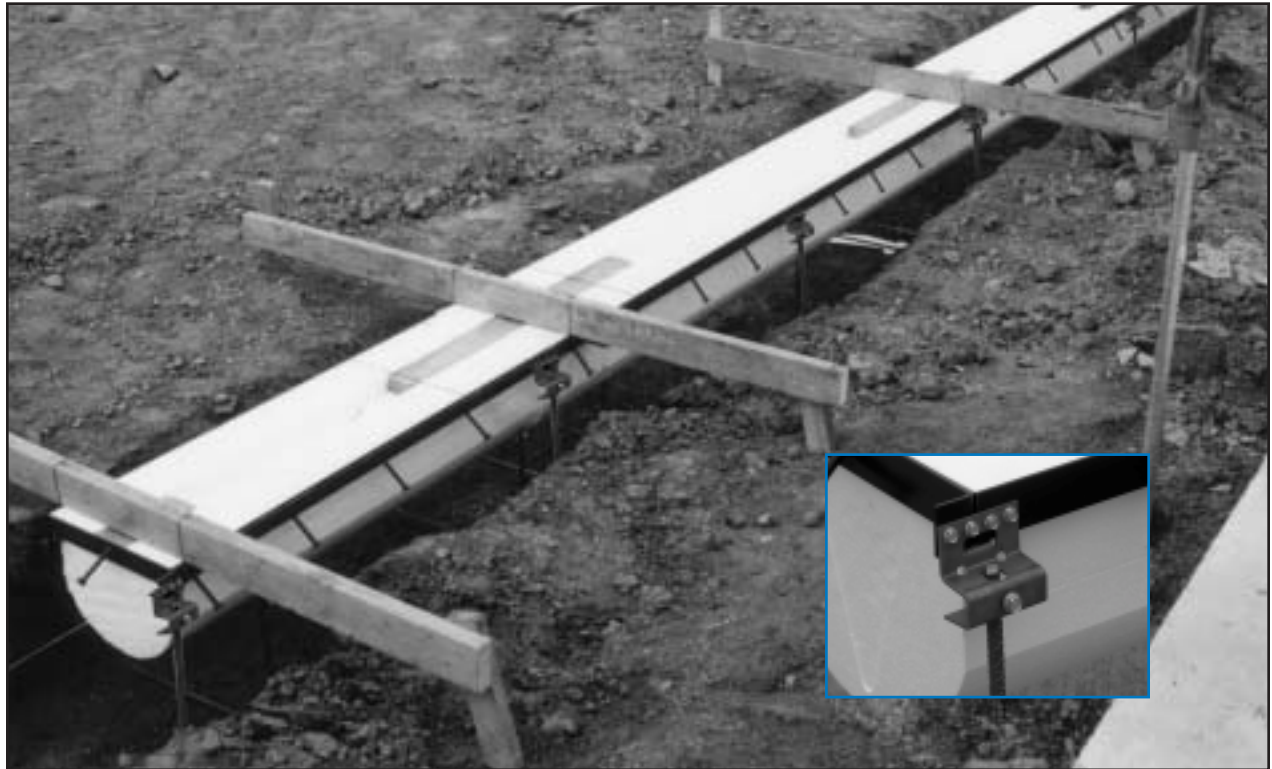



Trench Former⁷

Trench Former by ABT,⁷ Inc., manufacturer of Polydrain,⁷ is a pre-engineered, cast-in-place concrete forming system for forming drainage trenches, catch basins, utility chases and voids in concrete placements.

Consisting of:

- * Expanded polystyrene (EPS) form sections
- * Embedded steel inlay rails
- * Patented no-float legs
- * Grates or covers

The system eliminates the need for heavy forming materials, keyways and waterstops normally required with trench drains and utility chases.

Standard Design

TF-14 former shapes are made from lightweight expanded polystyrene (EPS) to provide the most widely used trench size, 12" wide with a 1.04% built-in slope and radius bottom.

Custom Design

Trench Former is available in various widths, depths, slopes, and trench bottom configurations. For custom Trench Former needs contact our technical sales support team at 1-800-438-6057.

Precision Engineering

Precision is engineered into the product, eliminating the need for highly skilled and expensive labor. Accurate to within $\frac{1}{16}$ in., the former shapes have longitudinal grooves for alignment, and integral deforming grooves for easy removal.

Low Cost

When using the Trench Former System, installation costs can be reduced by 33% or higher. It requires no heavy machinery (except for excavation) and is constructed in a fraction of the time of previous methods.

Easy Installation

A non-structural anchoring slab placed over the no-float legs holds the formwork firmly in place without elaborate anchoring.

Concrete can then be placed monolithically, eliminating cold joints, keyways, and waterstop material. Forms can be removed in 24 hours or can be left in place indefinitely, preventing unsafe open pits on the job site. There are no piping alignment problems because piping is butted to the formwork and cast-in-place.

Environmentally Sound

The EPS forms are manufactured without CFC's and can be disposed of safely and easily. It's also recyclable and makes a high quality fuel for commercial incinerators as well as being land fill-able.

Low Maintenance

The permanent system components are designed to be maintenance friendly. Quarterly inspections are recommended, but the built-in slope, radius bottom, and low roughness co-efficient help to eliminate debris buildup.

U.S. Patents #5,348,421; #5,393,171; #5,281,051; #5,478,169; #5,573,350 and #5,702,204. Other patents pending. Trench Former is a registered trademark of ABT, Inc.

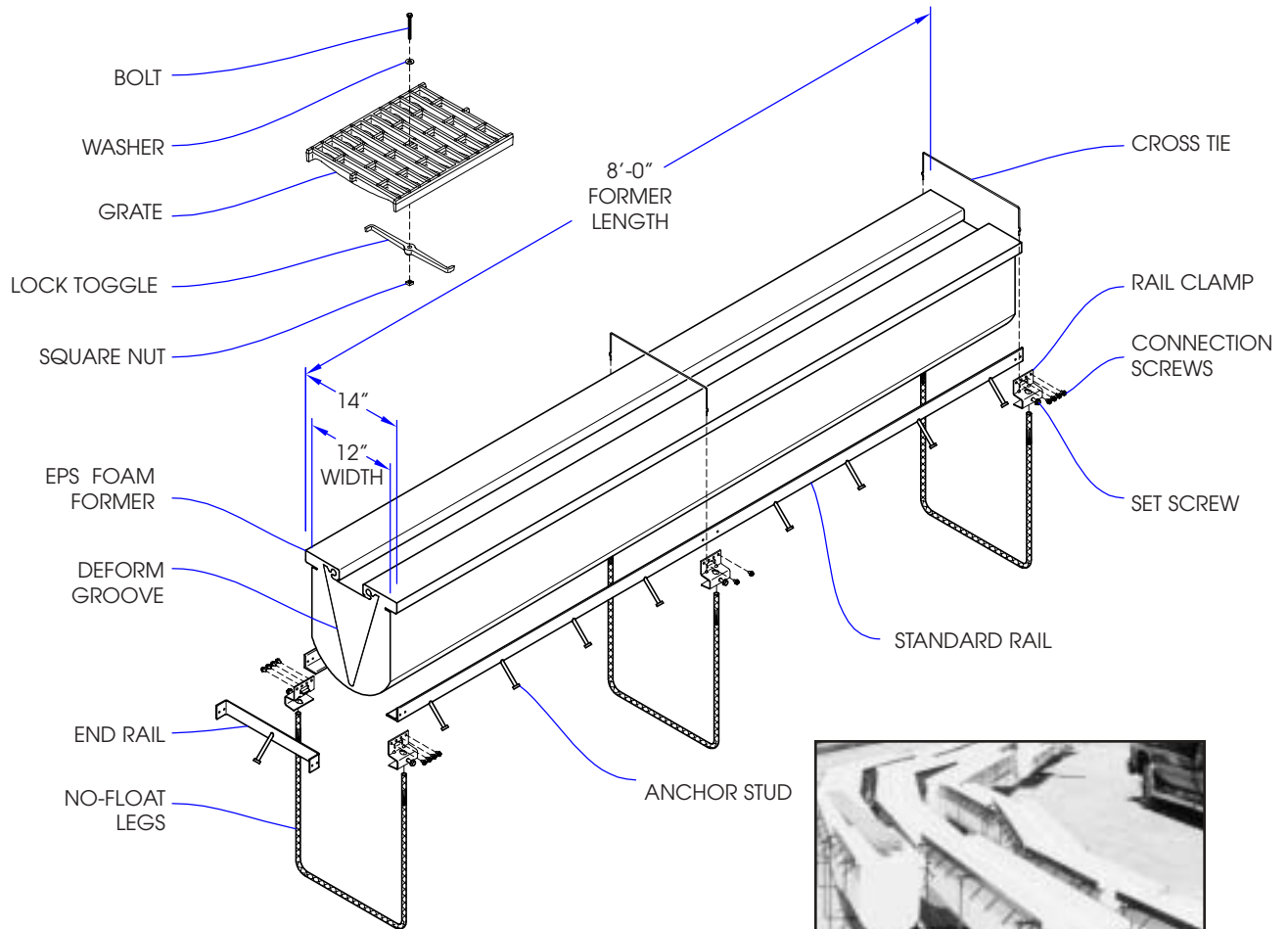

TF-14 is the standard stock Trench Former system. Its components are made in the most commonly constructed size. TF-14 consists of 8 ft. pre-sloped form segments. The 24 stock segments can be used together to create a continuously sloped 192 ft. trench.

Each segment is engineered to a 1/8 in. per ft. slope (1.04%). The EPS forms create 12 in. wide trenches with a 6-1/2 in. radius bottom and a 14 in. grate seat area.

They have integral deforming grooves for easy removal and full length longitudinal grooves for coplanar rail spacing and alignment. Six non-sloping, 4 ft. or 8 ft. long forms are available throughout the system to create longer continuous runs.

The steel angle rails include anchoring studs welded on 11 in. centers to the outside corners. U-shaped no-float legs (#4 rebar) attach to rail clamps on each rail. Each rail end is designed to accept a rail clamp which connects adjacent rail segments.

Prefabricated L-rail and T-rail assemblies allow for field installation of 90° turns anywhere in the pre-sloped layout.

Outlet piping is butted to an annular groove made in the EPS form prior to concreting. For trench junctions or for large outlet sizes, four catch basins are provided. A wide selection of retainable grates and solid covers is available for various loadings.





EPS Forms

Our EPS forms include unique deforming grooves which keep the foam segments together during the concrete pour, and alignment slots in the top which are sized for a standard 2 x 4. Each 8 ft. pre-sloped length has a radius bottom and a built-in 1.04% (1/8 in./ft.) slope. Non-sloping lengths are 4 ft. and 8 ft. Part numbers are marked on the deep (down-stream) end in the color that matches its corresponding no-float U-leg.

Part #see page 6

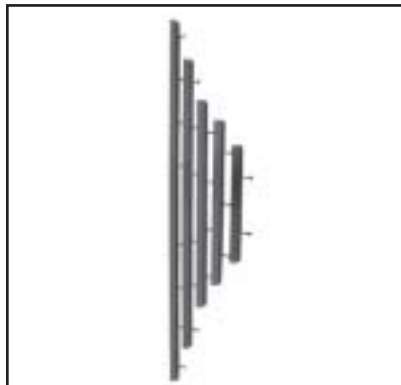

Rails

1-3/4 x 1-3/4 x 3/16 in. structural steel rails are manufactured in five lengths: 8, 6, 4, 3 and 2 ft. The ends of all the rails are punched to receive the Rail Clamps (#1802) on which to mount the no-float legs and cross ties. Anchor studs are welded on 11 in. centers. The selection of rail sizes lets you meet any desired trench layout to within 6 in. without modification. Standard rail components are a powder coated black epoxy paint and are also available in hot dip galvanized if required.

- Part #1492 (2 ft.)
- Part #1493 (3 ft.)
- Part #1494 (4 ft.)
- Part #1496 (6 ft.)
- Part #1498 (8 ft.)

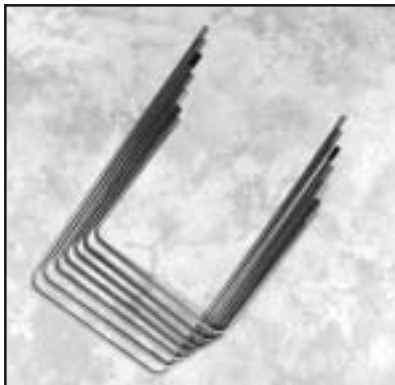

No-Float Legs

The eight no-float leg sizes are color coded to match their corresponding form sections for easy installation. This patented feature is at the heart of the Trench Former no-float guarantee. Legs are secured to rails by set screws for stability and strength.

Part #see page 6



Cross-Ties

Cross-ties help hold rails tight to the foam former for consistent spacing of grates and aesthetically pleasing trenches.

Part #1897TW



End Frames

End frames close off the end of a trench run preventing concrete from entering the end of a trench. Rail Clamps (#1802) will attach end frames to rails.

Part #1498EF

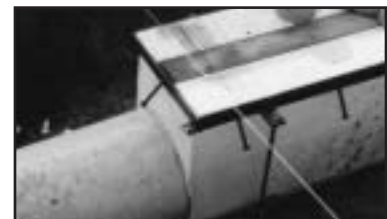

Outlet/Connects

Prior to concrete placement and where local plumbing codes allow, butt outlet pipe to former or connect former to catch basin.

As with any typical cast-in-place system, standard fittings may be used to connect to sanitary sewer or stormwater piping.

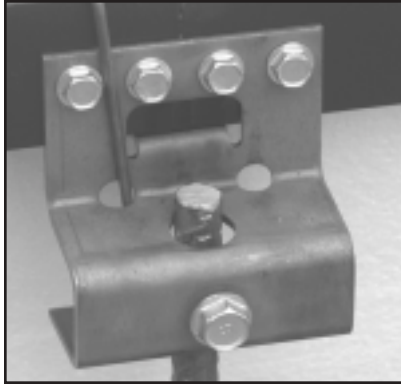

Rail Clamp

Rail clamps are used to connect all rail segments, end frames, and catch basin frames to prevent uneven joints. No-float legs and cross-ties are positioned into opposing rail clamps. The rail clamps provide longitudinal alignment, stiffness, and vertical adjustment.

Part #1802



Former Release

Former Release is a non-petroleum based product which is to be applied to all EPS forming surfaces. It provides good concrete release properties without attacking EPS foam and is available in one and five gallon cans. Form Release is best applied with a brush.

Part #.....1336 (1GL)
 Part #1336 (5GL)

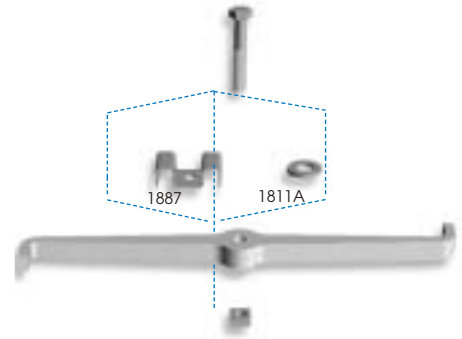

Grate Locking Devices

Lock toggles tie down grates by turning against the trench wall and securing to the underside of the steel rail.

Assembly #1811A
 (Fits 1500.14, 1502.14, 1503.14 and 1504.14)
 Assembly #1887
 (Fits 1468.14)



T-Rail Assembly

When used in conjunction with a 4 ft. rail, a trench intersection is easily formed. Ideally, the intersecting form number should be a minimum of six part numbers less than the main trunk run. (For example, a #24 trunk run would be entered by a #18 intersection or less.) Minimum is Form #7.

Part #1499T



L-Rail Assembly

The L-rail assembly is used for right and left turns anywhere in trench layout. When the 8 ft. form is cut, and an adjacent set of 4 ft. rails is used, the form is fully utilized and the form/rail joints line up. Minimum is Form #7.

Part #1499L

Schematic

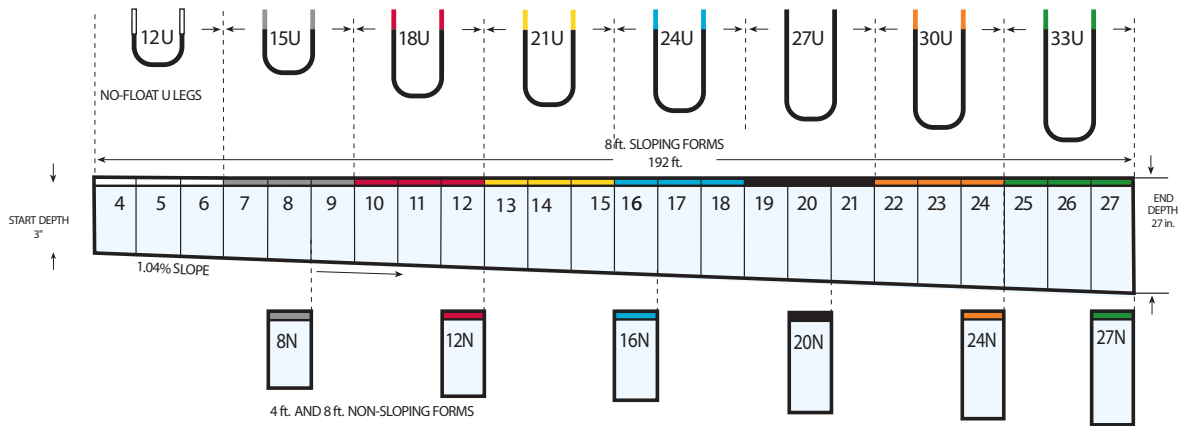

The colors shown correspond to the actual colors on the parts you will receive and are designed to simplify identification of complementary parts.

Technical Data

Color Part No-Float Form Length Form Depth Flow X-Section Maximum Rate of Flow w/o Grates Capacity
Code Number Leg # ft. Min in. Max in. ft sq. gal/m cfs lbs. gal.

| Color | Part Code Number | No-Float Leg # | Form Length ft. | Form Depth Min in. | Form Depth Max in. | Flow X-Section ft sq. | Maximum Rate of Flow gal/m | Maximum Rate of Flow cfs | w/o Grates lbs. | Capacity gal. |
|-------|------------------|----------------|-----------------|--------------------|--------------------|-----------------------|----------------------------|--------------------------|-----------------|---------------|
| | 4 | 12 | 8 | 3 | 4 | 0.07 | 63 | 0.1 | 49.1 | 4 |
| | 5 | 12 | 8 | 4 | 5 | 0.15 | 206 | 0.5 | 49.7 | 9 |
| | 6 | 12 | 8 | 5 | 6 | 0.24 | 387 | 0.9 | 50.4 | 14 |
| | 7 | 15 | 8 | 6 | 7 | 0.32 | 591 | 1.3 | 50.1 | 19 |
| | 8 | 15 | 8 | 7 | 8 | 0.40 | 809 | 1.8 | 50.8 | 24 |
| | 8N | 15 | 4 | 8 | 8 | 0.40 | — | — | 27.5 | 13 |
| | 9 | 15 | 8 | 8 | 9 | 0.48 | 1038 | 2.3 | 52.4 | 29 |
| | 10 | 18 | 8 | 9 | 10 | 0.57 | 1274 | 2.8 | 53.1 | 34 |
| | 11 | 18 | 8 | 10 | 11 | 0.65 | 1516 | 3.4 | 53.7 | 39 |
| | 12 | 18 | 8 | 11 | 12 | 0.73 | 1762 | 3.9 | 54.4 | 44 |
| | 12N | 18 | 4 | 12 | 12 | 0.73 | — | — | 28.8 | 23 |
| | 13 | 21 | 8 | 12 | 13 | 0.81 | 2012 | 4.5 | 56.1 | 49 |
| | 14 | 21 | 8 | 13 | 14 | 0.90 | 2264 | 5.0 | 56.7 | 54 |
| | 15 | 21 | 8 | 14 | 15 | 0.88 | 2519 | 5.6 | 57.4 | 59 |
| | 16 | 24 | 8 | 15 | 16 | 1.06 | 2775 | 6.2 | 59.0 | 63 |
| | 16N | 24 | 4 | 16 | 16 | 1.06 | — | — | 31.6 | 33 |
| | 17 | 24 | 8 | 16 | 17 | 1.14 | 3034 | 6.8 | 59.7 | 68 |
| | 18 | 24 | 8 | 17 | 18 | 1.23 | 3293 | 7.3 | 60.4 | 73 |
| | 19 | 27 | 8 | 18 | 19 | 1.31 | 3553 | 7.9 | 62.0 | 78 |
| | 20 | 27 | 8 | 19 | 20 | 1.39 | 3815 | 8.5 | 62.7 | 83 |
| | 20N | 27 | 4 | 20 | 20 | 1.39 | — | — | 33.5 | 43 |
| | 21 | 27 | 8 | 20 | 21 | 1.47 | 4077 | 9.1 | 64.3 | 88 |
| | 22 | 30 | 8 | 21 | 22 | 1.56 | 4340 | 9.7 | 66.0 | 93 |
| | 23 | 30 | 8 | 22 | 23 | 1.64 | 4604 | 10.3 | 66.7 | 98 |
| | 24 | 30 | 8 | 23 | 24 | 1.72 | 4868 | 10.8 | 67.3 | 103 |
| | 24N | 30 | 4 | 24 | 24 | 1.72 | — | — | 36.3 | 53 |
| | 25 | 33 | 8 | 24 | 25 | 1.80 | 5133 | 11.4 | 69.0 | 108 |
| | 26 | 33 | 8 | 25 | 26 | 1.89 | 5398 | 12.0 | 69.6 | 113 |
| | 27 | 33 | 8 | 26 | 27 | 1.97 | 5664 | 12.6 | 70.3 | 118 |
| | 27N | 33 | 4 | 27 | 27 | 1.97 | — | — | 37.9 | 60 |

— = non-sloping forms. Also available in 8 ft length.

NOTE: Roughness coefficient (n) = 0.013

For max. rate of flow on sloped sites use the following conversion equation: $Q = \frac{\text{Flow}}{0.102} S^{1/2}$ Where S= Grade Slope + 0.0104



Slotted Grate (Heavy Duty)

| | |
|-------------------|------------------|
| Part # | 1502.14 |
| AASHTO H-20 Rated | Yes |
| Material | Ductile Iron |
| Open Area | 65% |
| Dim (LxWxT) | 18 x 13.75 x 1.5 |
| Weight | 16.0 lbs. |



Slotted Grate (Extra Heavy Duty)

| | |
|-------------------------|------------------|
| Part # | 1503.14 |
| Heavy Aircraft Traffic. | Yes |
| Perpendicular Only | |
| Material | Ductile Iron |
| Open Area | 41% |
| Dim (LxWxT) | 18 x 13.75 x 1.5 |
| Weight | 60.0 lbs. |



Pedestrian (ADA) Grate

| | |
|-------------------|------------------|
| Part # | 1504.14 |
| AASHTO H-20 Rated | Yes |
| Material | Ductile Iron |
| Open Area | 22% |
| Dim (LxWxT) | 18 x 13.75 x 1.5 |
| Weight | 50.9 lbs. |



Trim Banded Bar Grate

| | |
|---------------------|------------------|
| Part # | 1468.14 |
| Fed. RR-F-624E Ped. | Yes |
| AASHTO H-20 Rated | No |
| Material | Galvanized Steel |
| Open Area | 88% |
| Dim (LxWxT) | 24 x 13.75 x 1.5 |
| Weight | 18.6 lbs. |



Solid Cover

| | |
|-------------------------|------------------|
| Part # | 1500.14 |
| Heavy Aircraft Traffic. | Yes |
| Perpendicular Only | |
| Material | Ductile Iron |
| Open Area | 0% |
| Dim (LxWxT) | 18 x 13.75 x 1.5 |
| Weight | 55.3 lbs. |

TF-14 Catch Basins are available in both the 1600 and 1900 series. The catch basins can be used at any point throughout a trench run as well as a termination point or a stand alone area drain. Both series utilize deforming grooves and a no-float leg system. The components are color coded for easy installation.

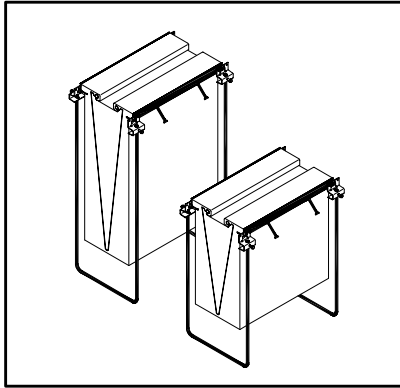

1900 Series Catch Basin

The 1900 series catch basins are 12 in. wide x 24 in. long flat bottom units, manufactured in 24 in. and 36 in. depths. They utilize 24 in. long rail (#1492), standard TF-14 grates, locking devices, and end rails.

- Part #1900 (24 in. deep)
- Part #1901 (36 in. deep)

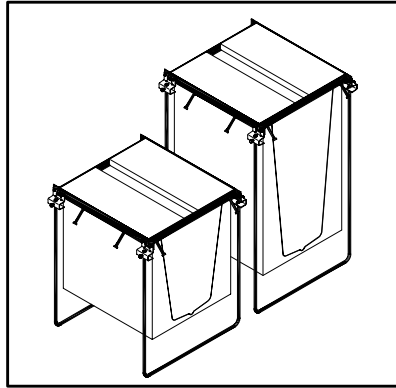

1600 Series Catch Basin

The 1600 series catch basins are 21 in. x 24 in. and are available in both 24 in. and 36 in. depths. This series uses two 24 in. long frame rails (#1492) and two end frames (#1492EF).

- Part #1610 (21 X 24 X 24 in.)
- Part #1611 (21 x 24 x 36 in.)

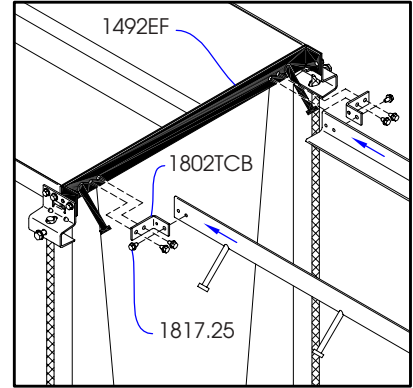

Special End Rail

If a 1600 series catch basin is used at the end of a trench run, brackets connect to rails and end frames. This aligns and retains the end of the trench rails for a secure and precise fit.

- Part #1492EF
- Part #1802TCB
- Part # 1817.25

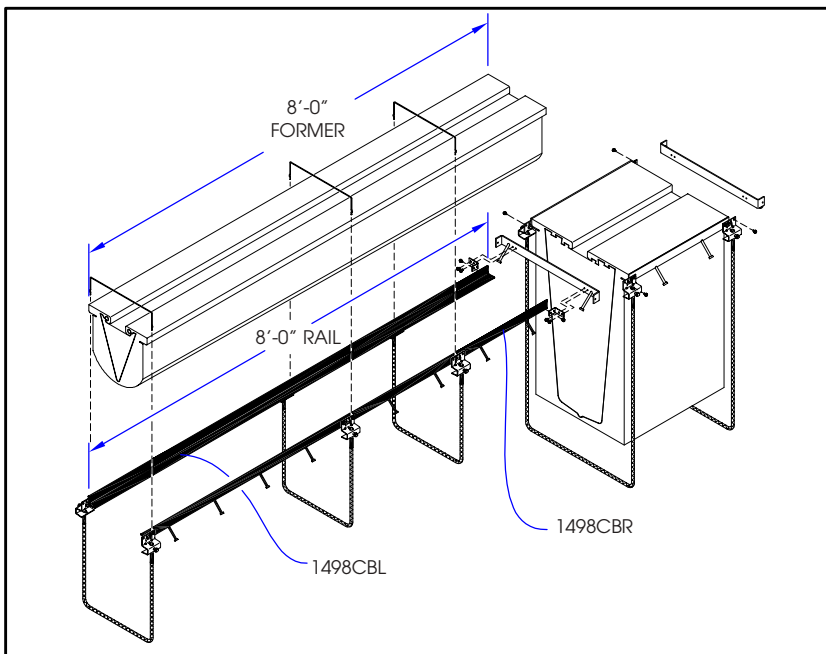

TF-14 Assembly Schematic



1600 Series Grate

The 1600 catch basin grate is 23 x 24 x 1-1/2 in. cast iron and meets AASHTO H-20 Load Rating.

- Part #1604

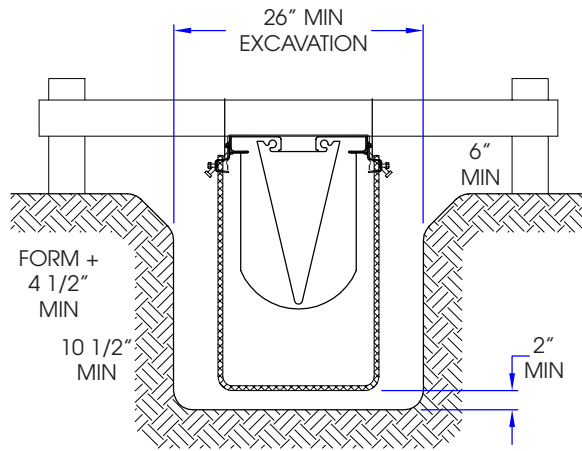

Figure 1

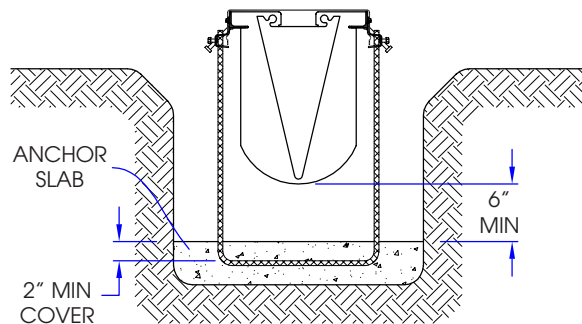

Figure 2

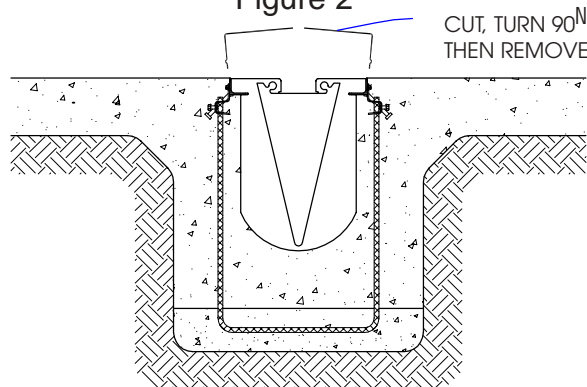

Figure 3

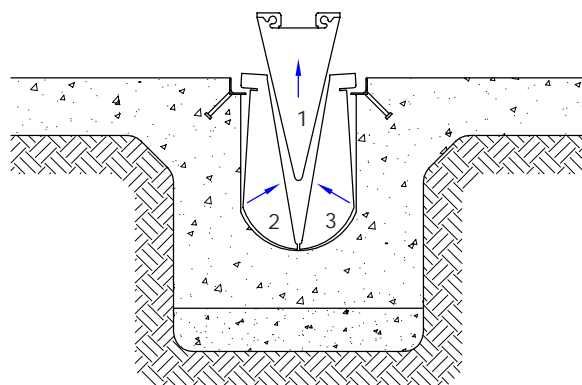

Figure 4

Excavation

Excavation must provide for 6 inches (minimum) on both sides of the former and 10-1/2 inches (minimum) on the bottom. Structural slabs may require additional excavation. Consult your structural engineer. Bottom allowance includes 4-1/2 inches of clearance for the no-float U-legs and anchoring slab. Excavate to match former numbers provided. Each 8 foot section has 2 equal length U-legs, so the excavation should be a series of step-down sections.

Assembly

Apply the Former Release to the bottom and sides of all the formers. **DO NOT USE PETROLEUM BASED FORM RELEASE** - it will severely attack the EPS foam. Lay out the former and rail sections along the excavation in the proper sequence. Former and U-legs are color-coded for easy assembly. Match color on U-legs to the colored part number marked on the end of former. Assemble all rails, legs, and formers. Connect rail clamps to the rails, one on an end and one in the middle. With the former upside-down, push each rail into the groove of the former. Attach the U-legs to the rails by inserting each U-leg into the holes of opposing rail clamps. Use set screws to hold the U-leg in position. Turn the former upright and install a Cross Tie tightly across rails to ensure a snug fit and precise grate seat dimension. Join sections together into 16 foot lengths using the rail clamps.

Component Placement

Begin installation at the outlet / deep end of the trench. Attach a length of supporting lumber near each joint (at anchor studs). Hold the top of rail to finished grade and attach lumber to grade stakes. See Figure 1. Butt the next section against the one in position, attach to rail clamps, and then set to elevation. To assist in alignment once sections are in place, 2 x 4's can be fitted inside the alignment groove and nailed to the supporting lumber.

Concrete Placement

Place a concrete anchoring slab wall-to-wall and end-to-end in the bottom of the excavation. Cover the U-legs with 2 inches (minimum) of concrete. Allow this slab to set hard, and then remove the supporting lumber. See Figure 2. Monopour trench bottom and walls, vibrating at the rails for good consolidation. While finishing concrete, remove Cross Ties by cutting in half, turning 90° and lifting them out. See Figure 3.

Deforming

After 24 hours, you can deform the trench. Drive a pry bar between former and trench floor, exerting upward force. The center V-shaped section will break free and can be easily removed. Pull remaining pieces from the wall and remove. See Figure 4.

DISCLAIMER

The customer and the customer's architects, engineers, consultants and other professionals are completely responsible for the selection, installation, and maintenance of any product purchased from ABT, and EXCEPT AS EXPRESSLY PROVIDED IN ABT'S STANDARD WARRANTIES, ABT MAKES NO WARRANTY, EXPRESS OR IMPLIED, AS TO THE SUITABILITY, DESIGN, MERCHANTABILITY, OR FITNESS OF THE PRODUCT FOR CUSTOMER'S APPLICATION. Copies of ABT's standard warranties are available upon request.

PolyDrain®, Trench Former®, and TF-14® are registered trademarks of ABT, Inc.

TF-14 has revolutionized trench drain installation and performance. Check out the differences between TF-14 and hand forming.

TF-14

- Creates monolithic trench walls and floor.
- Rail accuracy assured by precision cut foam shapes.
- Hundreds of feet installed per day with a 2 laborer crew.
- Simple wood supports used for holding sections to grade.
- Standard radius bottom improves flow.
- Forms can be left in for jobsite safety.
- Fast, low cost deforming.
- All necessary trench components available from one source in off-the-shelf design.

Hand Forming

- Requires installation of keyway and waterstop at cold joint.
- Complex carpentry skills required to create coplanar rails.
- 2 skilled carpenters average 50 feet per day.
- Requires sturdy and complex wooden form work.
- Square bottom creates turbulence and deposits.
- Open pits are hazardous and collect jobsite debris.
- Forms must be re-used to be economical
- Three separate sources for materials create risk of dimensional inaccuracies.





The Oil Water Separator is the best solution where petroleum contaminants must be isolated and removed — from bus barns to chemical transfer stations to airports.

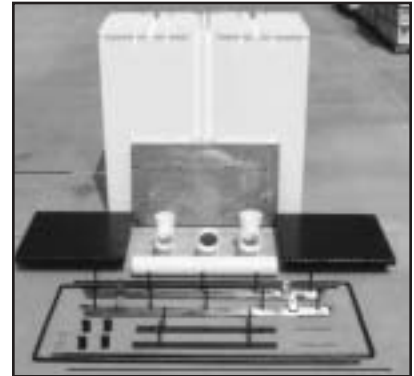

Environmentally Sound

As environmental regulations become more stringent, separators are becoming essential in facilities where oil and grease are present in the drainage stream. Unlike other systems, our [Oil Water Separator](#) provides static separation of solid debris and free oils or other non-soluble chemicals from drain water before discharge. Unlike others, our Oil Water Separator is fabricated with a lightweight, easily installed forming system that does not require the use of heavy equipment, providing a cost effective system of unequalled efficiency.

Easy to Install

An EPS form is precut to create a cast-in-place concrete tank. Cutouts in the form locate and position all the pipe connections and form a retainer slot for the insertable full width overflow weir.

The steel angle frame is 1-3/4 x 1-3/4 x 3/16 in. structural steel with welded anchor studs and no-float leg brackets. The frame rails and no-float legs are attached to form a lightweight, sturdy assembly during installation.

The covers are reinforced diamond plate steel designed for either pedestrian or H-20 heavy duty loading, and include locks for security and safety. The complete assembly includes all internal pipes and fittings.

A secondary geomembrane containment liner is available to provide additional protection against leakage. The liner is polymer coated synthetic fabric combining flexibility and puncture resistance.

Standard Features

- Three storage capacities — 160, 240, and 320 gallon.
- Three flow capacities — 21, 31 and 42 gallons per minute.
- Full perimeter steel anchor frame.
- Patented no-float installation legs.
- Internal PVC piping and fittings.
- Preformed deforming grooves.
- Full width overflow weir to maintain laminar fluid flow.
- Ability to inspect discharge stream.

Oil Water Separator

PRODUCT: Oil Water Separator formed of cast-in-place concrete using pre-manufactured forming system manufactured by ABT, Inc. PO Box 837, 259 Murdock Road, Troutman, NC 28166, (800) 438-6057.

OIL WATER SEPARATOR: Size: 160, 240, 320 Gal. holding capacity with maximum depth of 48 in. Provide with full width overflow weir for laminar fluid flow at maximum separation efficiency. Provide unit with oil level inspection tube, all internal piping, and optional geomembrane liner for secondary containment of contaminants. Provide steel rails with integral anchoring legs for securing formwork assembly to earth without penetrating subgrade. Provide steel plate covers for pedestrian or AASHTO H-20 loading, as required. Provide covers which lock down to rails for security and safety.

Suggested Specifications (short form)

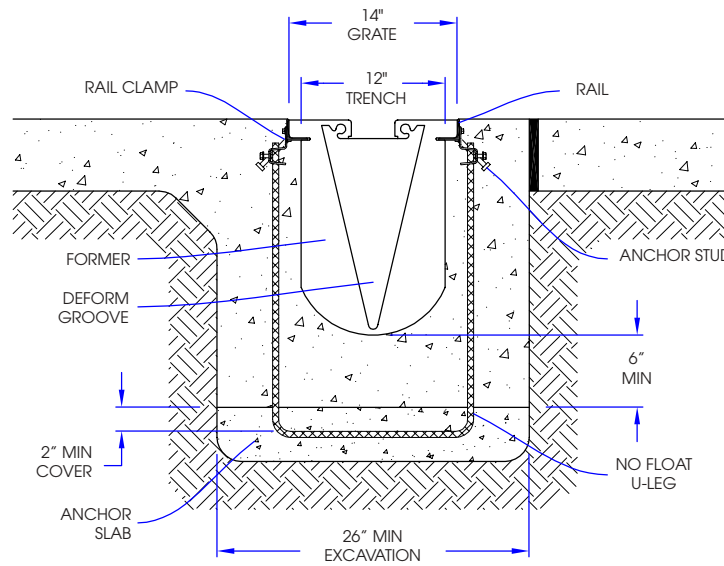

TF-14 Cross Sectional View

TF-14 Pre-Manufactured Forming System

PRODUCT: Cast-in-place trench drains and catch basins, formed using the Trench Former TF-14 Pre-Manufactured Forming System, manufactured by ABT, Inc., PO Box 837, 259 Murdock Road, Troutman, NC 28166 (800)438-6057.

TRENCH DRAIN FORMS: Fabricated of expanded polystyrene to provide dimensional accuracies within 1/16 in. Forms establish coplanar relationship between opposing trench rails for precise grate width dimension. Forms: 8 and 4 ft. forming 12 in. wide, radius bottom trench with 14 in. wide grate seat, with integral slope of 1.04% (1/8 in. per ft.), or non-sloping as indicated, with full length deforming grooves to assist in easy form removal, and top groove for 2 x 4 in. alignment members.

TRENCH RAILS: Structural steel angle 1-3/4 x 1-3/4 x 3/16 in. including concrete anchors at 11 in. centers. Provide all rail ends with means for precision alignment with adjacent rail ends. Provide U-shaped anchoring legs allowing for formwork assembly to be anchored to earth without penetrating subgrade and to assure that formwork will not float during concrete placement. Provide tie wires that assure constant rail spacing and grate seat dimension.

GRATES: TF-14 part # ____ fabricated of ____, meeting minimum load class of ____. Grates locked down to steel angle rail with appropriate locking device assembly. Provide locks, offering security and safety while providing an obstruction-free trench.



Other quality drainage products by ABT, Inc.

ABT, INC.

The information contained within is believed to be accurate but not guaranteed to be so. The customer should evaluate the suitability and safety of these products for any application. ABT assumes no liability for the end results since the conditions of installation and use are beyond the control of ABT. Concrete specifications, placement, reinforcement and structural considerations are the responsibility of the customer. ABT reserves the right to change the price, availability, specifications, and content of any of its products, literature or other information in all media at any time without notification.

PO Box 837 ■ 259 Murdock Road ■ Troutman, NC 28166 ■ TEL 704-528-9806 ■ FAX 704-528-5478
Toll Free 800-438-6057 ■ Email:sales@abtdrains.com ■ www.abtdrains.com ©ABT, Inc. Printed in the U.S.A. 3/06